

Names of Components

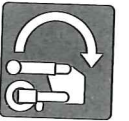

Unfolding the Wheelchair

Caution When lowering an armrest, take care that your fingers, hair, clothing, etc., do not get caught in the gap between the armrest and backrest. This could lead to injury.

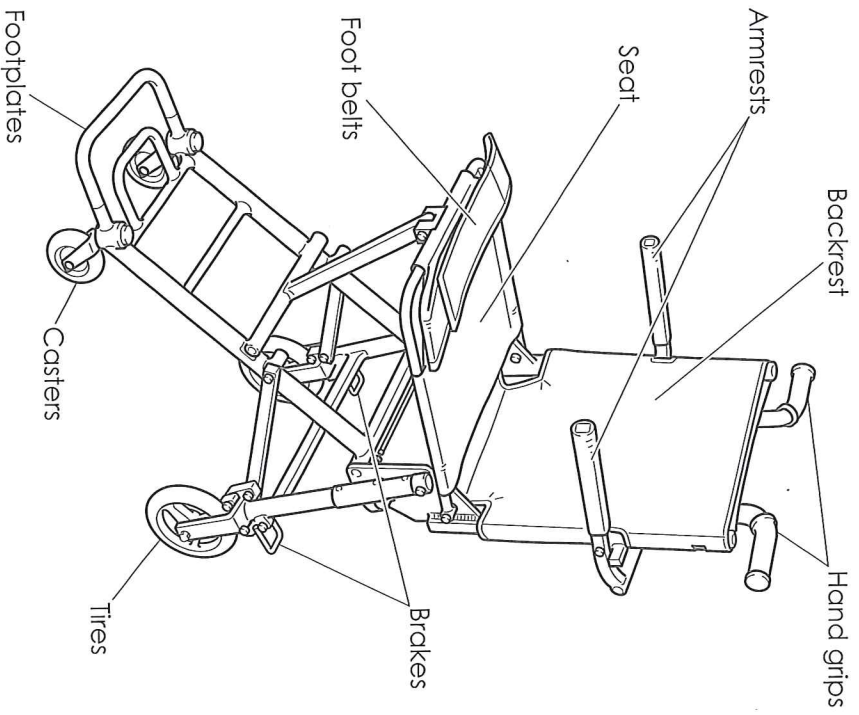
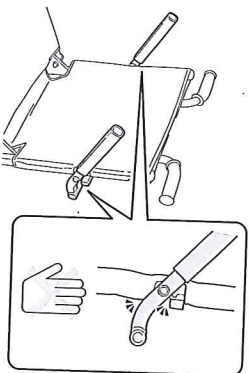

1 Grasp the bar beneath the hand grips and the bar of the footrests and lift them up to open the chair. Continue opening the chair until you hear it click and lock in place.

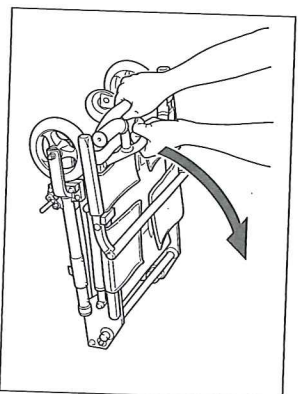

2 Lift the seatback handles and lower the armrests.

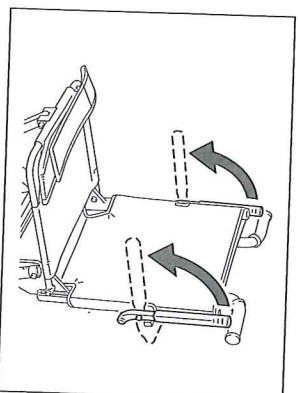

NAH-207

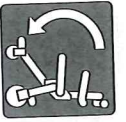

Folding the Wheelchair

Caution

Do not attempt to fold the wheelchair while the user is still seated in it. This could lead to injury or tip the chair over.

- 1 Remove the person seated in the wheelchair, fold the footplates outward, and stow the foot belts.

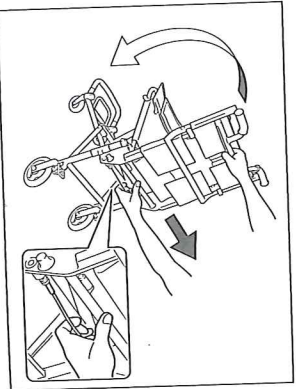
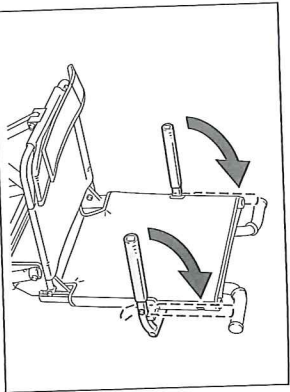
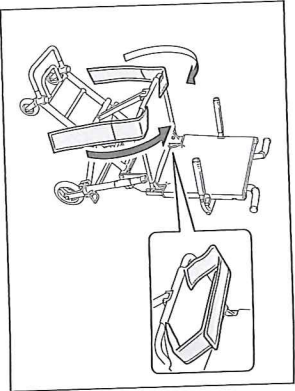

- 2 Pull the black cable at the back in the direction of the arrow. While holding the bar below the hand grips, fold the wheelchair.



Being Seated in the Wheelchair

Caution

- When being seated or unseated in the wheelchair, be sure to set the brakes on both wheels.
- Adjust the foot belts as necessary to an optimal position. If they are too tight or too loose, they could lead to injury.
- When being seated or unseated in the wheelchair, do not concentrate your body weight on the footplates as this could cause the wheelchair to lean or break the footplates.
- The handle at the backrest is for raising and lowering the armrests. Do not hang items from it or place too much force on it.

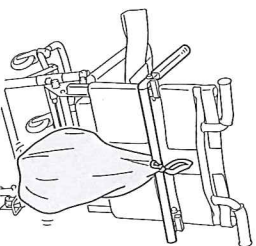

- 1 Being Seated in the Wheelchair

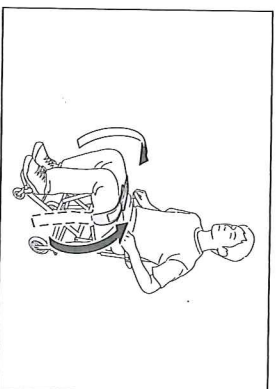
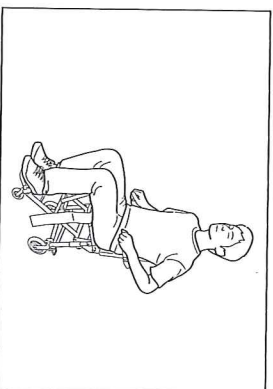

- 2 Adjust the belt with your feet on the footplates.



Setting the Brake



Caution

Be sure to set the brakes in the following situations. Be sure to set the brakes on both wheels.

- When being seated or unseated in the wheelchair.
- When making adjustments to the wheelchair
- When no one is seated in the wheelchair and moving away from it.

- 1 Brakes are installed on both of the rear wheels.

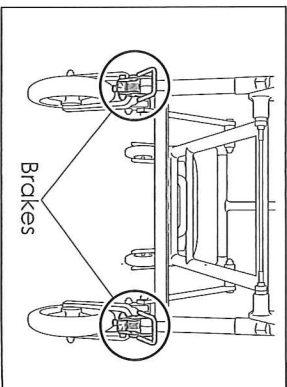

- 2 Step on the brake lever to push it downward.

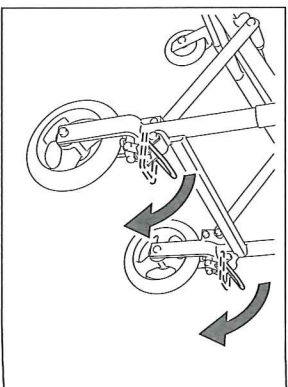

- 3 To release the brake, return the brake lever to its original position.

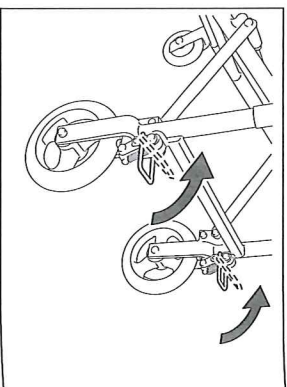

Care of Your Wheelchair

We recommend regular inspections and cleaning to allow the wheelchair to be used enjoyably for a long period of time.

Cleaning

■ Metal and Plastic Components

- Remove mud and dirt from the wheelchair by soaking a cloth in a mild detergent and wiping them away. After that, use a dry cloth to wipe off the detergent.
- Clean the wheelchair at least once a month.

■ Around Axles

- If dirt or mud get on the wheelchair axles, wipe it off using a dry cloth.
- Wipe off dirt and mud from the axles and surrounding components at least once a week using a damp cloth. After that, wipe these components dry of the moisture.
- Oil the axles about once every six months.

■ Seat Section

- Remove dirt and mud from the seat by soaking a cloth in a mild detergent and wiping them away. After that, use a dry cloth to wipe off the detergent.
- Do not put the back rest in water or wash it.
- If the backrest is dried with a hairdryer or by putting it in a clothes dryer, the heat will damage the material and change its shape.

■ Storage

- Store the wheelchair in a clean, dry place. Storing it in a place with high moisture content will lead to rust and corrosion.
- If the wheelchair is not used for a long period of time, make sure it operates properly before using it.
- If the wheelchair is not used for three months or more, have an authorized supplier perform an inspection before using it.